

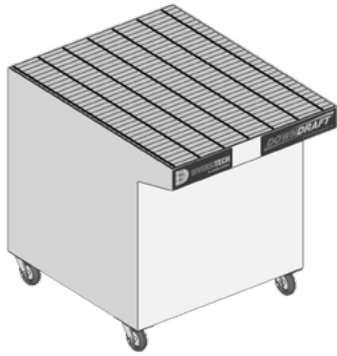

DIVERSITECH

Operation & Maintenance Manual

Portable Downdraft Tables



Mini DD
Downdraft Table

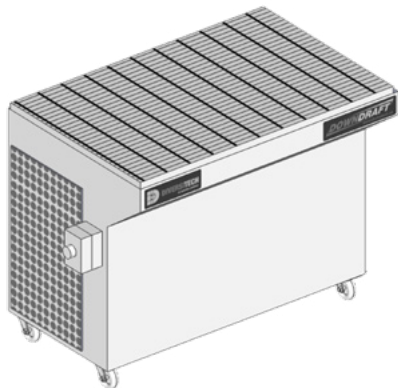
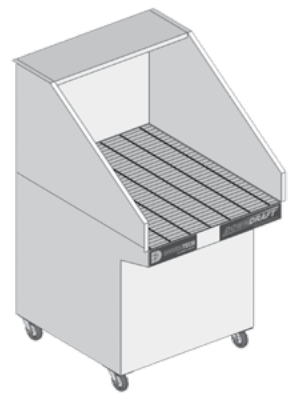

DD-2X4
Downdraft Table

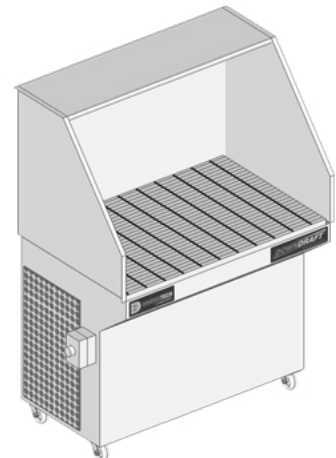

READ AND SAVE THESE INSTRUCTIONS

Visit our Website for more information on this product

www.diversitech.ca

2500 Alphonse Gariépy, Montreal, Quebec H8T 3M2
Tel: 1.800.361.3733 | Fax: 1.514.631.9480 | info@diversitech.ca

Table of Contents

SECTION 1 – SAFETY PRECAUTIONS OF FUME & DUST EXTRACTION/COLLECTION	3
1.1 Symbols	3
1.2 User Responsibility	3
1.3 Fume Extraction Hazards	3
1.4 Dust Collection Hazards	3
SECTION 2 – SPECIFICATIONS	4
2.1 Model Configuration & Description	4
2.2 Product Specifications	4
2.3 Filter Specifications	5
2.4 Dimensions	5
SECTION 3 – SETUP / INSTALLATION	6
3.1 To Setup or Install Safely	6
3.2 Un-Packaging	6
3.3 Selecting a Location	6
3.4 Installation	6
3.5 Preparing Unit for Operation	7
SECTION 4 – OPERATION	7
4.1 To Operate Safely	7
4.2 Controls	7
4.3 Pre-Use Checklist	8
4.4 Principles of Operation	8
4.5 DD-2x4 Pulse Filter Cleaning System	8
SECTION 5 – MAINTENANCE & TROUBLESHOOTING	9
5.1 To Maintain this Product Safely	9
5.2 Tools Required	9
5.3 Routine Maintenance Schedule	10
5.4 Filter Replacement DD-MINI	11
5.5 Filter Replacement DD-2x4	12
5.6 Troubleshooting Procedure	13
APPENDIX 1A – ELECTRICAL DIAGRAM MANUAL [120 VAC] Single Phase Power	14
APPENDIX 1B – ELECTRICAL DIAGRAM MANUAL [120/460/575v] 3-Phase Power	15
APPENDIX 2 – MAINTENANCE RECORD	16
APPENDIX 3 – REPLACEMENT PARTS	17
APPENDIX 4 – INSTALLING SIDE & BACK WALLS	18
NOTES.....	19
Limited Equipment Warranty	Back Cover
Freight Claims	Back Cover
Return Material Policy	Back Cover

SECTION 1 - SAFETY PRECAUTIONS OF FUME & DUST EXTRACTION/COLLECTION



READ
BEFORE
USE

This manual contains specific cautionary statements related to worker safety. To protect yourself and others, read this manual thoroughly and follow as directed before use. Not all hazards of fume & dust control are listed in this manual, and no hazards related to welding, cutting, grinding, painting, deburring or other applications are listed. Consult a qualified safety professional.



DO
NOT
USE

Do not use this equipment:

- To collect smoke, fumes, liquid vapors, or aggressive fumes such as acids.
- If the power cord has been damaged or ground (third prong) removed.
- Without the proper water level in the basin.

1.1 Symbols

This manual uses several symbols to highlight specific hazards. Be familiar with these symbols and when you see them in this manual, read adjoining warning text to avoid the hazard.



WARNING!
DANGER!



ELECTRIC
SHOCK



MOVING
PARTS



HOT
PARTS

1.2 Users Responsibility

- Improper use can be hazardous.
- It is your responsibility to follow all applicable ANSI, OSHA, UL, CSA, National & Local Fire Codes, and other regulatory guidelines covering the safe use of equipment that extracts fumes, collects dusts, and exhausts filtered air either indoors or outdoors.
- Before use, inspect the unit for damage and verify it is working properly.
- Only qualified persons should install, operate, maintain, or repair this unit.
- Do not modify or repair the unit with parts or accessories not supplied by the manufacturer.
- Consult filter manufacturer's instructions for filter use and reuse, including instructions for cleaning.

1.3 Fume Extraction Hazards







- Breathing smoke, fumes, or dusts produced in applications such as welding, cutting, grinding, painting, deburring are hazardous to user's health. Proper ventilation or use of well maintained fume extraction and/or dust collection equipment helps the user avoid these hazards.
- Breathable contaminants may not be visible or have an odor.
- Stop operation and leave the area immediately if 1) breathing becomes difficult, 2) experience dizziness, impaired vision, 4) or eye/nose/mouth irritation.

1.4 Dust Collection Hazards

- Dusts from many metalwork, woodwork, food production, pharmaceutical, other material processing applications can be combustible.
- Combining dusts from of different materials can introduce additional hazards as chemical reactions can happen in the airstream or in the water basin. Consult a qualified person before mixing more than one base material in a wet dust collector.
- Do not use or install equipment where any potential for combustible fumes or dusts are present, until a qualified person has indicated it is safe to do so.
- Never use or install equipment where the potential for combustible fumes or dusts are present without a fire/explosion protection system.
- If you are unsure if the product you purchased is correct for your application, call DiversiTech at 1-800-361-3733.

SECTION 2 - SPECIFICATIONS

2.1 Model Configurations & Description

Model	Features	Configurations	Applications	Includes
 <p>MINI-DD</p>	<ul style="list-style-type: none"> Open 38" x 30" worksurface Multi-stage spark arresstence baffling Industrial swivel-casters 	<p>WGD MINI-DD DD-2X4</p> 	<p>Welding, Grinding & Deburring Kit</p>	<ul style="list-style-type: none"> Side & Back Walls Metal Mesh Prefilter Grounding Lug
		<p>CAW MINI-DD DD-2X4</p> 	<p>Clean Air Workstation</p>	<ul style="list-style-type: none"> 48" tall Side & Back Walls Dust & vapor proof Light Kit Backdraft Hood
 <p>DD-2X4</p>	<ul style="list-style-type: none"> Open 48" x 32" worksurface Reverse-pulse filter self-cleaning system Multi-stage spark arresstence baffling Industrial swivel-casters 	<p>VOC DD-2X4</p> 	<p>VOC & Paint Kit</p>	<ul style="list-style-type: none"> Side & Back Walls Paint arresstor pre-filter Reversible carbon canister afterfilter
		<p>PLA DD-2X4</p> 	<p>Plasma Cutting Kit</p>	<ul style="list-style-type: none"> Side & Back Walls Metal Mesh Prefilter 2" Steel bar grating Slag collection baffle with 3/4" gravel

2.2 Product Specifications

Model	Motor (H.P.)	Power					Avg Airflow Pressure (CFM)	Static Pressure (in.)	Avg Face Velocity (FPM)	Cord Length (in.)	Noise @5ft. (dB)
		Phase (hz)	@120V (amps)	@230V (amps)	@460V (amps)	@575V (amps)					
Portable Downdraft Tables, Single Phase											
DD-MINI	1.0	1P/60Hz	12.0	---	---	---	1200	2.5	250	15	72
DD-2X4	1.5	1P/60Hz	14.2	---	---	---	1500	4.0	340	15	75
Portable Downdraft Tables, Three Phase											
DD-2X4	3.0	3P/60Hz	---	8.0	4.6	3.6	2600	4.0	450	---	75

2.3 Filter Specifications

Part Number	Filter Media	Filter Size	Cleaning Method	Filter Efficiency
MINI-DD Downdraft Tables				
S-MINI-0004	95% Paper Panel	20" x 25" x 2"	Disposable	MERV 8
S-MINI-0014	HEPA	20" x 25" x 4"	Disposable	MERV 17
S-MINI-0005	Metal Mesh Panel	20" x 25" x 2"	Water	---
DD-2X4 Downdraft Tables				
S-2x4-20NF	Nanofiber	20" Cartridge	Compressed Air	MERV 15
S-2x4-0001	80/20 Cellulose/Poly	20" Cartridge	Compressed Air	MERV 11
S-2x4-0002	Spunbond Poly	20" Cartridge	Air + Water	MERV 11
S-2x4-CC50R	Carbon	20" Cartridge	Reusable	---
S-2x4-0030	HEPA	40 SQ. FT.	Disposable	MERV 17
S-2x4-0003	Metal Mesh Panel	16" x 25" x 1"	Water	---

For information on inspecting and cleaning filter, or purchasing replacement filters, contact DiversiTech at 1-800-361-3733.

2.4 Dimensions

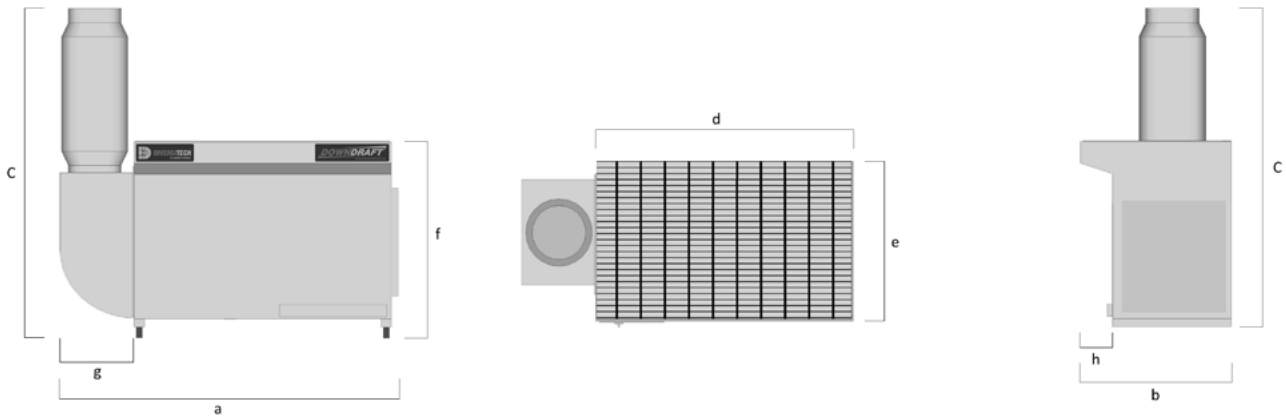

Model	Exhaust Diameter (in.)	Footprint (in.)			Worksurface (in.)		Table Height [f]	Exhaust [g]	Overhang [h]
		Width [a]	Height [c]	Length [b]	Width [d]	Length [e]			
Downdraft Tables, Standard Size									
DD-MINI	---	31	34.5	39	30	38	34.5	12	8
DD-2X4	---	49.5	39	32.5	48	32	39.5	10.5	8
DD-2X4 + SSS	8" x 1	60	69.5	32.5	48	32	39.5	10.5	8
Downdraft Tables, extended overhang									
DD-MINI-EO	---	31	34.5	45	30	44	34.5	12	12
DD-2X4-EO	---	49.5	39	38.5	48	38	39.5	10.5	12
DD-2X4-EO + SSS	8" x 1	60	69.5	38.5	48	38	39.5	10.5	12

SECTION 3 - SETUP / INSTALLATION

3.1 To Setup or Install Safely



- Do not place unit near flammables or combustible surface.
- Refer to **SECTION 2: Specifications**, to know the electrical requirements of the unit you are installing and ensure adequate input power that is properly sized, rated, and protected.
- This unit must be grounded for safe operation.

3.2 Un-Packaging

1. Immediately upon receiving the unit, carefully examine the carton for damage during transit.
2. Remove packing material.
3. Avoid tipping or inverting during handling.
4. The item serial number, model, and electrical ratings are listed on the nameplate. Record this information in the Maintenance Record provided in **APPENDIX 2: Maintenance Record**, or your own preventative maintenance system.

3.3 Selecting a Location

- Choose a location where the unit will be used, near the operator.
- Choose a location sufficiently close to a grounded power source.

3.4 Installation

- Electrical Connection for units requiring: 1-phase (120V) plug-type connection:
 - Your unit may be equipped with a [115V/20A] fitting, requiring a NEMA 5-20R power receptacle.
 - See **APPENDIX 1A: Electrical Diagram** for wiring instructions.
- Electrical Connection for units requiring: 3-phase (230/460/575V) direct connection:
 - See **APPENDIX 1B: Electrical Diagram** for wiring instructions.
 - Have a certified electrician install electrical connection according to local regulations.
 - All three power leads must be connected to L1, L2 and L3 on the contactor.
 - This unit must be grounded for safe operation.
 - If on start-up the downdraft table seems to be lacking performance or the table sounds very loud, the motor is most likely running in the reverse direction. Reversing leads L1 and L3 will reverse motor rotation in the right direction.
- For units requiring Compressed Air:
 - Supply 80-90 PSI of CLEAN, DRY, compressed air to the bulkhead bushing on the side of the unit.
 - The air tank in the downdraft table is fabricated to allow a maximum of 90 PSI, DO NOT attempt to supply air pressure greater than 90 PSI without a properly installed pressure regulator.
 - Moisture in airline can damage filter(s); use an air dryer if required.
- Special Installation steps for table options:
 - Side & Back Walls Installation – See **APPENDIX 4A: Installing Side & Back Walls**
 - Welding, Grinding, Deburring Packages & Kits
 - Plasma Cutting Packages & Kits
 - Spray Painting Packages & Kits

3.5 Preparing Unit for Operation

- Remove all packaging and shipping protection before use, in accordance with **SECTION 3.2: Un-Packaging**
- Select a location appropriate for use that complies with all safety instructions contained herein, and **SECTION 3.3: Selecting a Location**
- Confirm installation of correct input power source, compressed air, and any special installation requirements, in accordance with **SECTION 3.3: Installation**. Look at the manufacturer's label located on the exterior of the unit and ensure the source is correctly sized in terms of Voltage and Amperes.
- Prior to use in your application, turn the unit ON, and perform a function test. To do so:
 - Turn switch to ON position
 - LOOK: Is the unit level, stable, and that nothing is obstructing the extraction path?
 - LISTEN: Does the motor and suction sound smooth and within expected volumes?
 - FEEL: Place your hand on top of the unit and sense for unexpected vibration. Place your hand in front of the intake surface and sense for expected level(s) of suction.
- Inform all potential users of this equipment where they may find and review this manual.

SECTION 4 - OPERATION

4.1 Operate Safely



- Read and understand **SECTION 1: Safety Precautions** and **SECTION 4: Operation** before use
- Read and understand all Material Safety Data Sheets and Manufacturer's instructions of all process materials, consumables, and equipment used in conjunction with this equipment.
- Keep away from all mechanical moving parts including motor, gears, and other pinch points.
- Do not use product without first confirming if a Spark Arrestor is required and installed for the type of dust, or fumes you are extracting and/or collection. If you are unsure, call a DiversiTech representative at 1-800-361-3733.

4.2 Controls

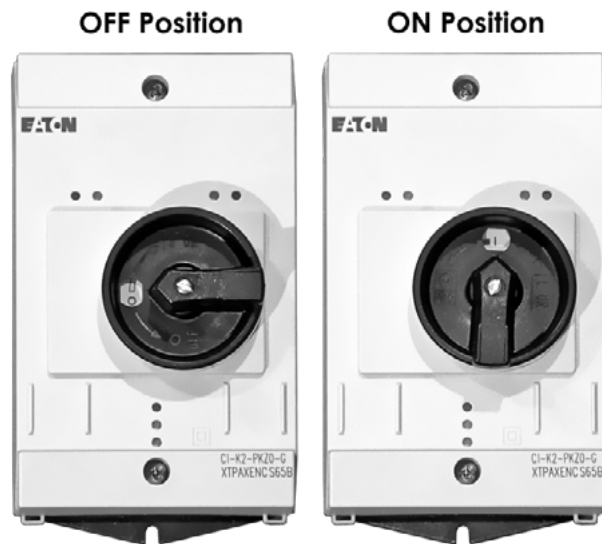

4.3 Pre-Use Checklist

- Prior to use in your application, turn the unit ON, and perform a function test. To do so:
 - Turn switch to ON position
 - LOOK: Is the unit level, stable, and that nothing is obstructing the extraction path?
 - LISTEN: Does the motor and suction sound smooth and within expected volumes?
 - FEEL: Place your hand on top of the unit and sense for unexpected vibration. Place your hand in front of the intake surface and sense for expected level(s) of suction.
- Inform all potential users of this equipment where they may find and review this manual.

4.4 Principles of Operation

This product is designed to capture and clean smoke and dust from light & medium duty welding, soldering, and grinding applications. When operating, air is drawn in through the table surface grating, passes through spark-arrestor baffling, then through the table's filtration system, and exhausted through the side exhaust.

This product consists of seven basic components:

1. Protective table surface grating(s)
2. Multi-stage spark-Arrestance baffling
3. Table cabinet
4. Cartridge Filter
5. Motor/Blower Assembly
6. Push-button pulse filter cleaning system
7. Dust Drawer

4.5 DD-2X4 Pulse Filter Cleaning System

The DD-2X4 downdraft table is equipped with a pulse filter cleaning system. This system is controlled by a push-button affixed to the left side of the cabinet. It is recommended that you pulse the unit after every 4 hours of use.



SECTION 5 - MAINTENANCE & TROUBLESHOOTING

5.1 To Maintain this Product Safely



- Read and understand **SECTION 1: Safety Precautions** and **SECTION 4: Operation** before maintenance.
- Do not breathe the dust collected from product while changing/cleaning filters or performing maintenance on this product.



- Disconnect power before performing any maintenance on unit, including filter inspection. The input power to this unit is high voltage, and touching any live electrical parts can cause fatal shocks or severe burns. Do not touch live electrical parts.



- Keep away from all mechanical moving parts including motor, gears, and other pinch points while operating.



- Operating this unit causes some parts to heat to a point that will burn bare hands. Before maintenance allow parts to cool, or use proper tools and personal protection equipment during maintenance.

5.2 Tools Required



**EYE
PROTECTION**



RESPIRATOR



GLOVES



**WASTE
CONTAINER**

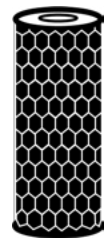

**REPLACEMENT
FILTER
(if required)**

5.3 Routine Maintenance Schedule

Warning

- Do not attempt to clean filters containing hazardous materials; refer to local regulations regarding disposal procedures as some captured contaminants may be flammable, explosive, or toxic.
- Cleaning cartridge filters with compressed air, water, or solvents can damage/destroy the filter media. Always check the manufacturer's instructions and specifications prior to cleaning.



Nanofiber / Paper-pleated filters

- Do not wet or clean the cartridge with any liquid, as it may cause the forming of unwanted blockage on the filter media.

Spunbond-poly filters

- Cleaning should be carried out on water-soluble materials only.
- Hydrocarbons may not be removable.
- The use of solvents may attack certain components of the filter. Consult the instructions and specifications prior to cleaning.

The manufacturer recommends the following routine maintenance based on light-duty use in normal operating conditions. Service more frequently if the unit is used in severe conditions.

Frequency	Manual Reference
Pre-Use	
<ul style="list-style-type: none"> · Perform pre-use inspection to ensure operating correctly. · If your application involves grinding, or any process that produces heat/sparks – lift the top grate and visually confirm that metal-mesh pre-filters (spark arrestors) are correctly seated on the baffle tray, and that no holes are present. 	4.3
Every (1) Week or 20 Operating Hours - Empty Dust Drawer/Clean Surface	
<ul style="list-style-type: none"> · Remove and wipe clean surface matting (if used). Remove dust drawer and deposit accumulated particulate in appropriate waste container. Refer to local regulations regarding disposal procedures as some captured contaminants may be flammable, explosive, or toxic. · Particles and stray material on the surface should be blown into the table towards the filter using compressed air. If a cushion grid mat (option) is used, direct particles into the table using a broom or brush. <p>Recommended frequency is one week, but may be less or more depending on application and duty cycle.</p>	
Every (4) Week or 80 Operating Hours - Inspect/Clean Cabinet	
<ul style="list-style-type: none"> · Remove and wipe down dust drawer, baffle trays, and metal mesh prefilters, depositing accumulated particulate in appropriate waste container. Refer to local regulations regarding disposal procedures as some captured contaminants may be flammable, explosive, or toxic. · Inspect, and clean if necessary the cabinet interior and dust drawer slats. · Inspect Metal Mesh Prefilter for any holes, or damage caused by hot sparks. Metal Mesh Prefilter can be cleaned by either blowing out with compressed air, or submerging and washing in warm, soapy water. 	
As Required – Replace Filter	
1. Replace Filter, see SECTION 5.4: Filter Replacement for instruction	
Every (12) months Inspect Basic Components	
1. Clean unreadable labels and exterior surfaces	
2. Cabinet: Check for loose wiring.	

5.4 Filter Replacement DD-MINI

As part of routine maintenance, it is important to visually inspect the filter. Replace the filter if you see:

1. Overloading or accumulation of particles
2. Rips, tears, or warping of filter media
3. Decreased table performance due to excessive static build up

To remove the filter, follow this 8-step procedure:

1. Unscrew knobs to open the cabinet door.



2. Remove Metal Mesh Prefilterer (if applicable).



3. Remove dirty filter.



4. Inspect cabinet interior for debris.



5. Insert clean replacement filter.



6. Ensure airflow indicator points in correct direction.



7. Replace Metal Mesh Prefilterer (if applicable).



8. Replace cabinet door.



5.5 Filter Replacement DD-2X4

As part of routine maintenance, it is important to visually inspect the filter. Replace the filter if you see:

1. Overloading or accumulation of particles
2. Rips, tears, or warping of filter media
3. Decreased table performance due to excessive static build up

To remove the filter, follow this 8-step procedure:

1. Open the cabinet door.



2. Unscrew twist knob to release the filter.

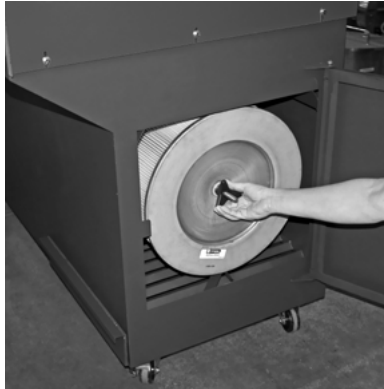

3. Slide filter out.

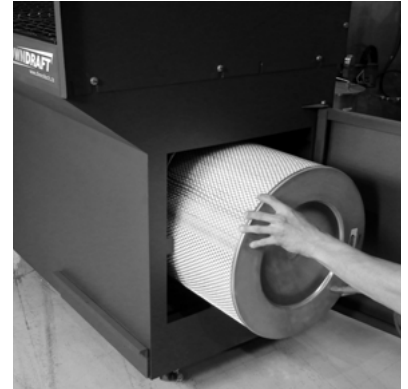

4. Inspect cabinet interior for debris.

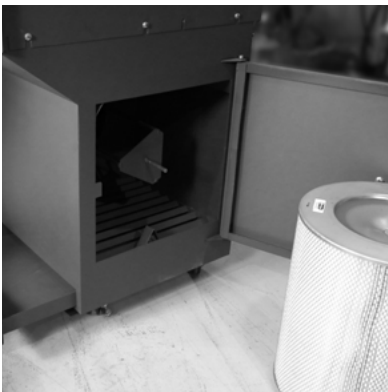

5. Open dust drawer and remove material.

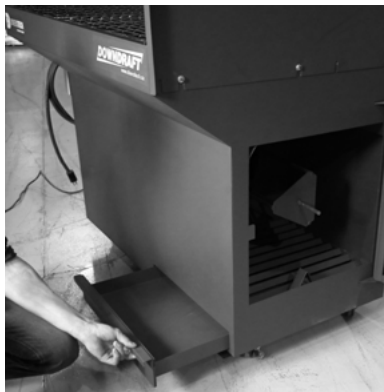

6. Insert clean replacement filter.

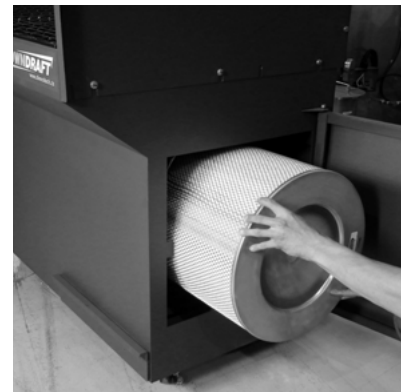

7. Screw twist knob to secure the filter

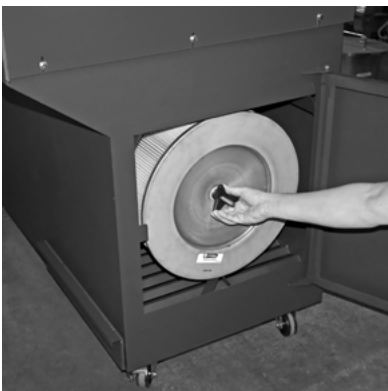

8. Close the cabinet door.



5.6 Troubleshooting Procedure

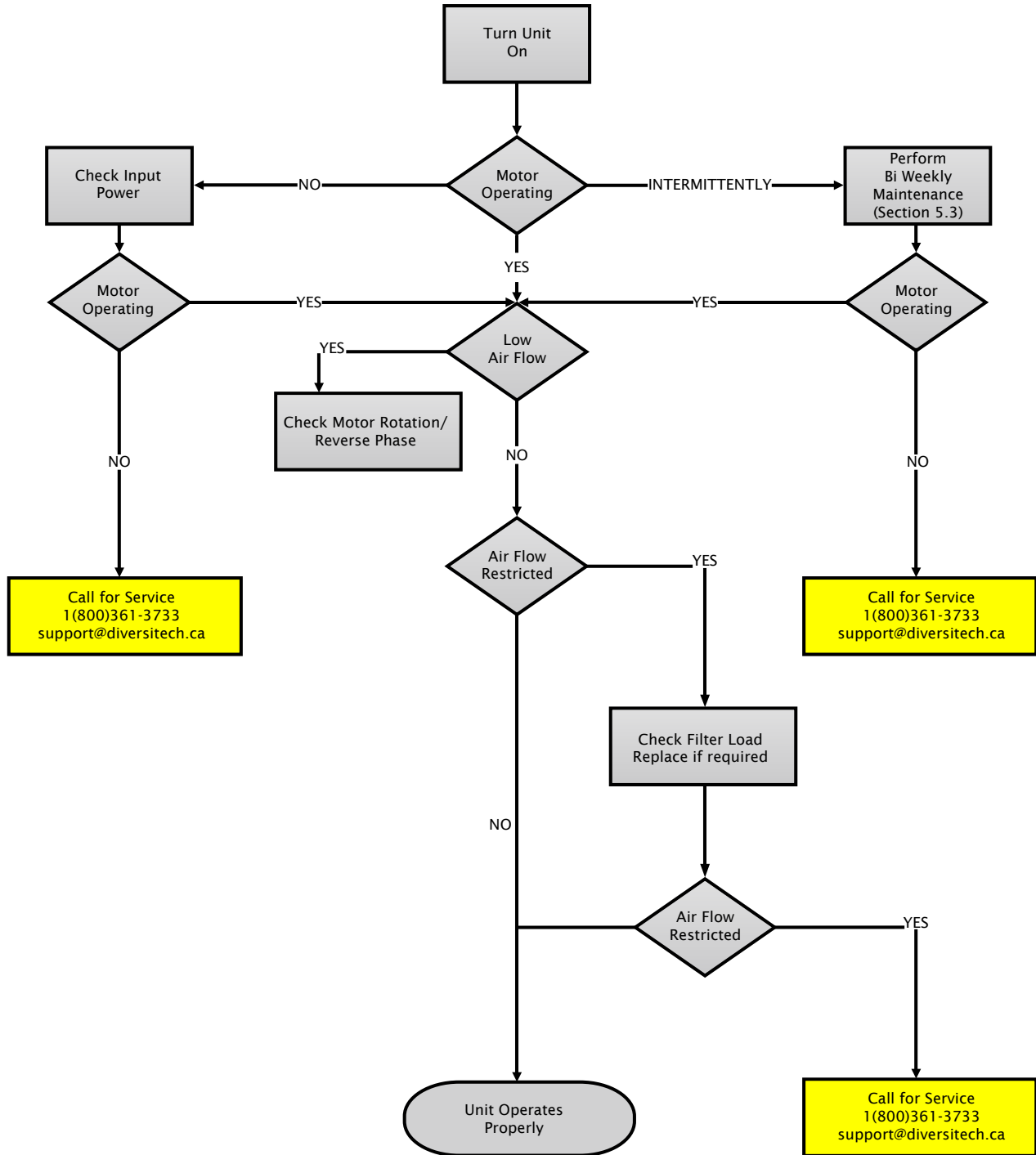

APPENDIX 1A - ELECTRICAL DIAGRAM MANUAL

[120 VAC] Single-Phase Power



**ELECTRIC
SHOCK
HAZARD**

Disconnect power before performing any maintenance on unit, including filter inspection. The input power to this unit is high voltage, and touching any live electrical parts can cause fatal shocks or severe burns. Do not touch live electrical parts.

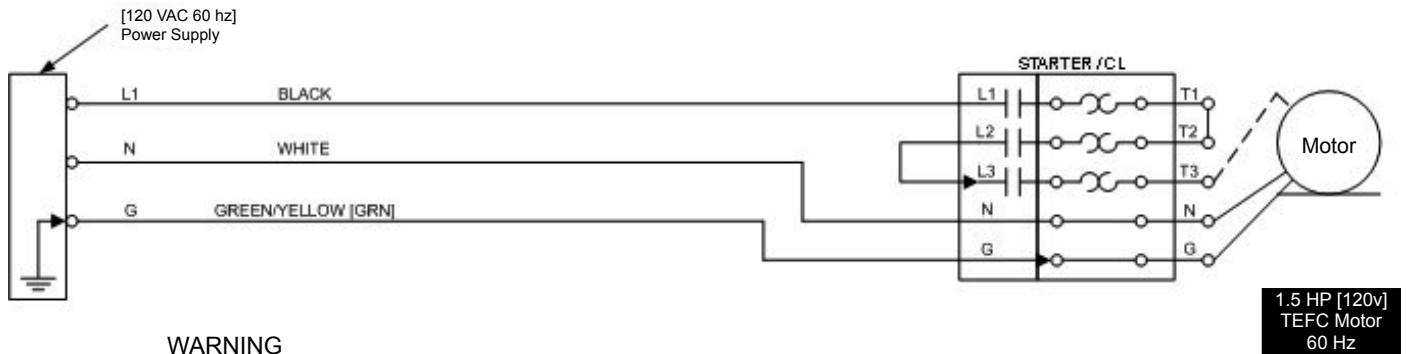

WARNING

Do not route auxiliary contact cable in the same conduit as motor cable

NOTE

Specific transformer wiring may differ depending on voltage configuration.

Units in brackets [] refer to imperial system values

APPENDIX 1B - ELECTRICAL DIAGRAM MANUAL

[230/460/575V] 3-Phase Power



ELECTRIC SHOCK HAZARD

Disconnect power before performing any maintenance on unit, including filter inspection. The input power to this unit is high voltage, and touching any live electrical parts can cause fatal shocks or severe burns. Do not touch live electrical parts.

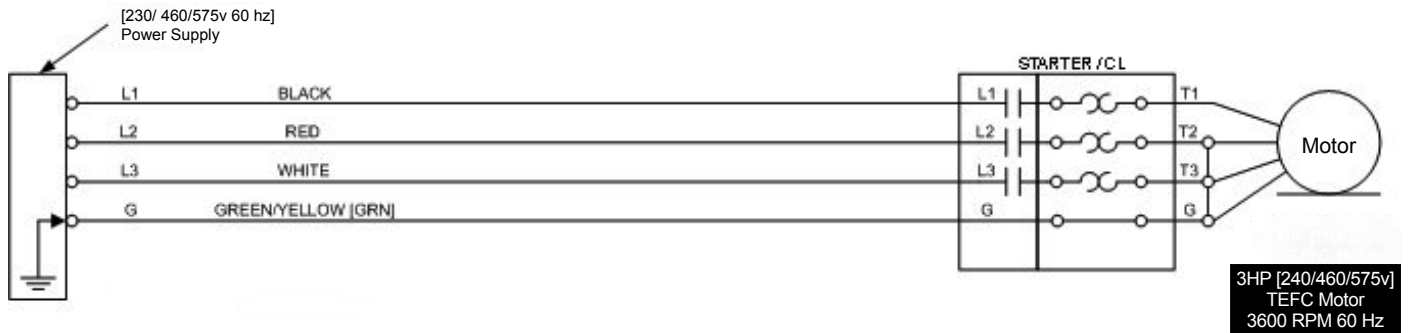

WARNING

Do not route auxiliary contact cable in the same conduit as motor cable

NOTE

Specific transformer wiring may differ depending on voltage configuration.

Units in brackets [] refer to imperial system values

APPENDIX 2 - MAINTENANCE RECORD

DiversiTech Inc. authorizes this page to be photocopied or otherwise reproduced as needed for management of maintenance records.

MANUFACTURER:	DIVERSITECH INC.	MODEL N°	DOWNDRAFT	SERIAL N°	
SERVICE LOCATION:				CONTROL N°	

Date	Description of Service	Serviced By	Location	Comments

Only use manufacturer approved replacement parts on this unit.

APPENDIX 3 - REPLACEMENT PARTS

PORTABLE DOWNDRAFT TABLES

ITEM NUMBER	DESCRIPTION	DD-MINI	DD-MINI 4	DD-2X4 (1.5 HP)	DD-2X4 (3 HP)
S-MINI-TG	Steel surface grate, 1" slots / 4" cross roads	✓			
S-MINI-010T1	1.0 HP TEFC Motor Blower Assembly [120/1/60]	✓	✓		
S-DXD-0907	3/4" Air Valve, DD			✓	✓
S-2X4-1312	Steel surface grate			✓	✓
S-CONE-0072	1.5 HP Motor Cone, Plastic			✓	
S-CONE-0073	3.0 HP Motor Cone, Plastic				✓
S-2X4-0017	55 lbs. bag of BC - 406 p activated carbon granules			✓	✓
S-2X4-0010	1.5 HP Composite Blower Wheel, backward inclined			✓	
S-2X4-1034	3.0 HP Composite Blower Wheel, backward inclined				✓
S-2X4-015T1	1.5 HP TEFC Motor [115/1/60]			✓	
S-2X4-030T2	3.0 HP TEFC Motor [230/3/60]				✓
S-2X4-030T4	3.0 HP TEFC Motor [460/3/60]				✓
S-2X4-030T5	3.0 HP TEFC Motor [575/3/60]				✓

REPLACEMENT FILTERS

Part Number	Filter Media	Filter Size	Cleaning Method	Filter Efficiency
MINI-DD Downdraft Tables				
S-MINI-0004	95% Paper Panel	20" x 25" x 2"	Disposable	MERV 8
S-MINI-0014	HEPA	20" x 25" x 4"	Disposable	MERV 17
S-MINI-0005	Metal Mesh Panel	20" x 25" x 2"	Water	---
DD-2X4 Downdraft Tables				
S-2x4-20NF	Nanofiber	20" Cartridge	Compressed Air	MERV 15
S-2x4-0001	80/20 Cellulose/Poly	20" Cartridge	Compressed Air	MERV 11
S-2x4-0002	Spunbond Poly	20" Cartridge	Air + Water	MERV 11
S-2x4-CC50R	Carbon	20" Cartridge	Reusable	---
S-2x4-0030	HEPA	40 SQ. FT.	Disposable	MERV 17
S-2x4-0003	Metal Mesh Panel	16" x 25" x 1"	Water	---

APPENDIX 4 - INSTALLING SIDE & BACK WALLS

To install the side & back walls, follow this 3-step procedure:

1. Prepare hardware



- Locate the bolt holes on the side and back of the cabinet
- Loosely attach bolt, lock washer, and washer
- Leave sufficient gap to fit the wall piece between the cabinet and the washers

2. Attach walls.



- Insert one back wall, and one side wall with lip facing outwards between the cabinet and the washers
- While resting the wall edge on the hardware, check for alignment of bolt holes

3. Fasten hardware

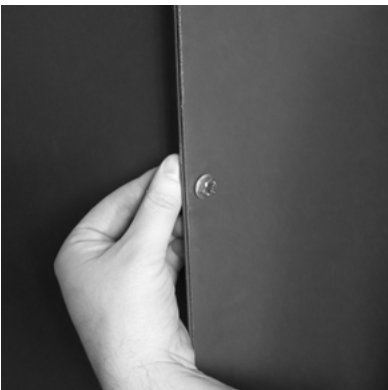

- Fasten bolt, lock washer, washer, net on the vertical edge – attaching one side wall to one back wall
- Repeat process to attach all walls
- Ensure to tighten hardware attaching walls to cabinet

NOTES

LIMITED EQUIPMENT WARRANTY

For a period of 2 years from the date of purchase, all Diversitech products are warranted to be free from defects in material, workmanship, and construction, when used in accordance with installation, maintenance instructions, and expressly stated proper use application(s). Diversitech Inc. will repair or replace, at our option, any defective parts which fail during the warranty period. This warranty is limited to replacement parts ONLY, and does not cover personal liability, property loss, normal wear; and does not cover losses resulting from (or due to) improper installation, inadequate maintenance, misapplication, misuse, or use above rated capacities.

FREIGHT CLAIMS

Shipments must be inspected upon arrival. All Diversitech units are sold ex-plant. Therefore, it is the receiver's responsibility to file any freight claims with the carrier for obvious or concealed damages. Damaged shipments must be refused at time of receipt, by consignee.

RETURN MATERIAL POLICY

Prior to the return of material, for whatever reason, a return manufacturing authorization number (RMA#) is required from the Diversitech customer service department. This procedure is necessary for proper control and handling of returned materials. Call 1-800-361-3733 or email support@diversitech.ca to obtain an RMA.

All material must be returned prepaid. Credit will be given for returns for warranty repair or replacement. Freight collect shipments, or freight without an RMA, will not be accepted. It is the shipper's responsibility to ensure that material being returned to Diversitech is adequately packaged for shipment to preclude damages.



Visit our Website for more information on this product
www.diversitech.ca

2500 Alphonse Gariépy,
Montreal, Quebec H8T 3M2
Email: info@diversitech.ca